

Model #

2089AFCAF

2089AFGSP

45"W Pacific Sound Bar Console

AFCAF = Caffè finish

AFGSP = Glazed Spice finish

Assembly Instructions

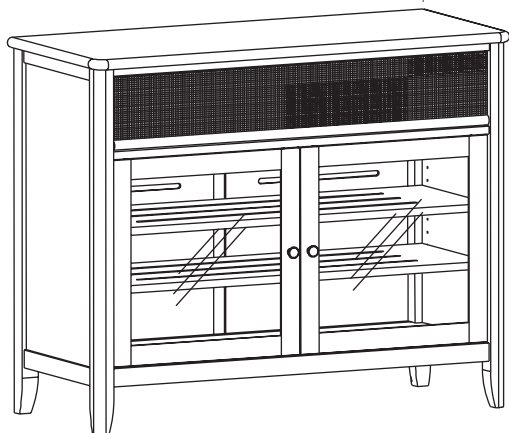

Congratulations!

This fine piece of furniture will make a gorgeous addition to your home. For the best results, read the Assembly Instructions before you begin your project.

! WARNING

Serious or fatal crushing injuries can occur from furniture tip-over. To help prevent tip-over:

- Place heaviest items in the bottom drawers.
- Unless specifically designed to accommodate, do not set TVs or other heavy objects on top of this product.
- Never allow children to climb or hang on drawers, doors or shelves.
- Never open more than one drawer at a time.

Correctly installing tipping restraints can reduce but does not eliminate tip-over risk.

! IMPORTANT NOTES:

- For normal household use only. **Not** recommended for commercial use.
- Unload items before you move this unit.
- Before you load or move this unit, tighten all screws and supports.
- Do not climb, sit or stand on this piece of furniture.
- Do not not overload the shelves on this unit.
- Handle the glass plates with care. Glass is fragile.
- Before you begin your project, completely read the Assembly Instructions.
- Store this item: 1- in its box; 2- in a dry place; 3- in temperatures that range from 40°F to 90°F (not on a cold and possibly damp cement floor).
- Periodically inspect your furniture for any loose glue joints, screws or any other problem that might affect the stability of your furniture. Tighten or repair as needed.
- This assembly requires two people.

DESIGN SUBJECT TO CHANGE WITHOUT NOTICE.



CALL US FIRST! Do not return this item to the store.

Service Policy: We will replace any part that is defective, missing or damaged during assembly. For a replacement part, contact Whittier Wood Products customer service department by phone, fax, mail or email.

Hours: Our friendly customer service staff can be reached Monday-Friday 7:00 a.m. to 5:00 p.m. (Pacific Time). You may leave a message 24 hours a day, seven days a week.

To Order: Provide the finish and furniture model number (upper left corner of this page), the part letter, production code, quantity needed, reason for replacement and your full name, address and telephone number.

Parts ship from our Eugene, Oregon factory within one or two business days from the time we receive your request. Please allow five to ten business days for delivery.

800-653-3336 • Outside the U.S. or Canada: 541-687-0213 • Fax: 541-687-2060
www.whittierwood.com • P.O. Box 2827 • Eugene, Oregon 97402, U.S.A.



P.O. Box 2827
Eugene, OR 97402 USA













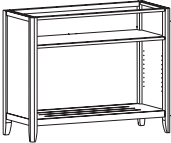

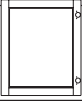



Production Code:

VN

08/11





















2089AFGSPa; 2089AFCAFa 45"W Pacific Sound Bar Console — Parts List

Please identify the parts and check that quantities received match those on this list.
If you need to replace a part, refer to the following letter and model number.

Part	Description	Quantity
A	Top (attached) 	1
B	Adjustable Shelf 	2
C	Case only 	1
D	Removable Back (installed) 	2
E	Door Frame (installed) 	2
F	Door Glass (installed) 	2
Ga	Speaker Door (attached) 	1
H	Glass Retainer (inserted) 	1
L	Shelf Bracket (attached) 	8
M	#6 x 1/2" Undercut Screw (inserted) 	8
O	Butler Hinge (attached) 	2
P	Magnetic Push Lock (attached) 	2
Q	#5 x 5/8" Flat Head Screw (inserted) 	12 (AFGSP) 0 (AFCAF)
R	Magnetic Plate (attached) 	2
S	#6 x 5/8" Undercut Screw (inserted) 	4 (AFGSP) 16 (AFCAF)
T	Hinge (attached) 	4
U	Hinge Plate (attached) 	4
V	#6 x 3/4" P.O. Screw 	16
W	Drawer Stop (attached) 	4

2089AFGSPa; 2089AFCAFa 45"W Pacific Sound Bar Console — Parts List continued

Please identify the parts and check that quantities received match those on this list.
If you need to replace a part, refer to the following letter and model number.

Part	Description	Quantity
X	Turn Button (attached) 	8
Y	#6 x 5/8" Philtruss Screw (inserted) 	28
ZA	Knob (attached) 	2
ZB	#8 x 1-1/4" Machine Screw (installed) 	2
ZD	Small Adjustable Glide (installed) 	4
ZE	#8 x 1-1/4" Pan Head Screw (inserted) 	18
ZG	#8 x 1-1/4" Black Screw (inserted) 	10
ZH	Flat Washer (inserted) 	2
ZI	Hex Bumper (attached) 	2
ZJ	Fitted Back (attached) 	1
ZK	Speaker Spacer 	2
ZL	Pad Strip (attached) 	4
ZM	Chain (attached) 	2
ZN	#6 x 1/2" Philtruss Screw (inserted) 	4
ZO	Top Cleat (attached) 	1
ZP	Push Plate 	2
ZQ	1/2" Dark Antique Brad 	4
ZR	Shelf Cleat (attached) 	1
ZS	#8 x 1" Pan Head Screw (inserted) 	4
ZT	3mm x 12mm Pan Head Screw (inserted) 	4
ZU	Insert Nut (inserted) 	4
TR	Tipping Restraint	2 sets

2089AFGSPa; 2089AFCAFa 45"W Pacific Sound Bar Console Assembly Instructions

Tool Required: Phillips Screwdriver, Hammer

Step one is optional: Attach the Push Plates when the console will be placed in a high-use area such as a retail sales floor where the Sound Bar Speaker Door (G) will be opened and closed often.

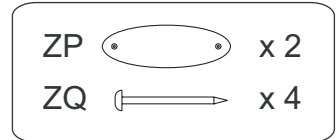
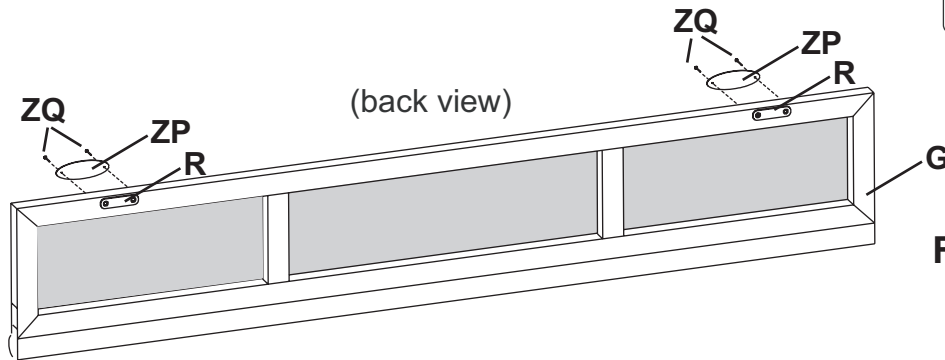

Fig. 1

1. Remove the Speaker Door (G) and place it face-up on a clean protected surface. Center a Push Plate (ZP) over the right Magnetic Plate (R) and attach with two 1/2" Dark Antique Brads (ZQ). Repeat for the left side. See Figure 2. Rehang the Door.



2. Place the console at its final destination. Rotate the Small Adjustable Glides (ZD) on the bottoms of the legs until the unit is level. See Figure 3 below.

Fig. 3

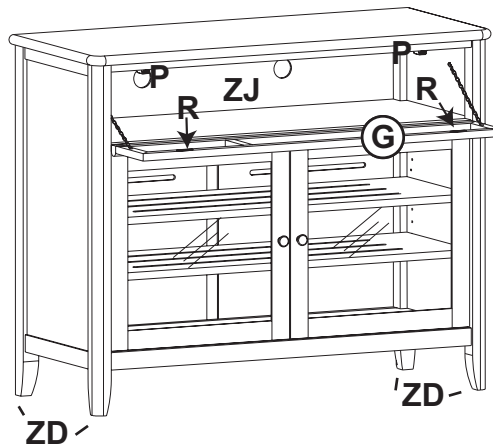

3. To open the Speaker Door (G), simultaneously press the Push Plates or both corners until the magnets release. Gently grasp the top middle of the door and pull it open. To shut the door, gently but firmly push on the Speaker Door (G) until the two Magnetic Plates (R) make secure contact with the Magnetic Push Locks (P). See Figure 3.

To install the sound bar from the back, remove the 16 #6 x 5/8" Philtruss Screws (Y) from the Fitted Back (ZJ) and pull it away. After installing the component, replace the Fitted Back (ZJ) and attach with 16 #6 x 5/8" Philtruss Screws (Y).

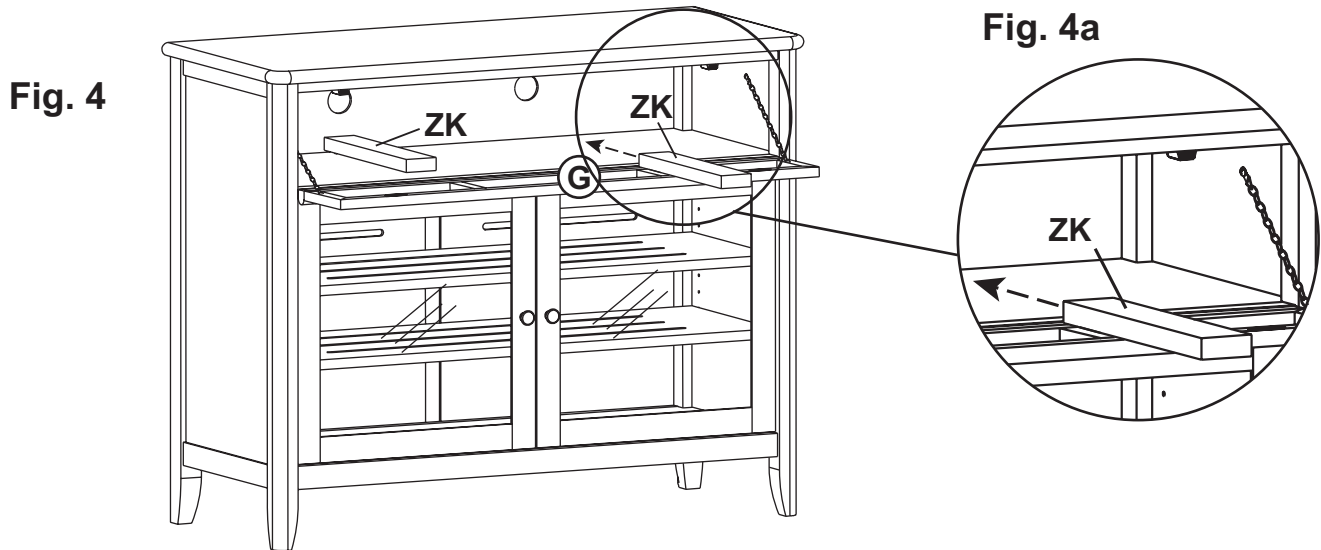

4. Your Sound Bar should sit above the edge of the open speaker door. If it does not, place the two Speaker Spacers (ZK) into the open area so the Pad Strips (ZL) sit on the shelf. Place the Sound Bar on top of the Spacers. See Figures 4 and 4a

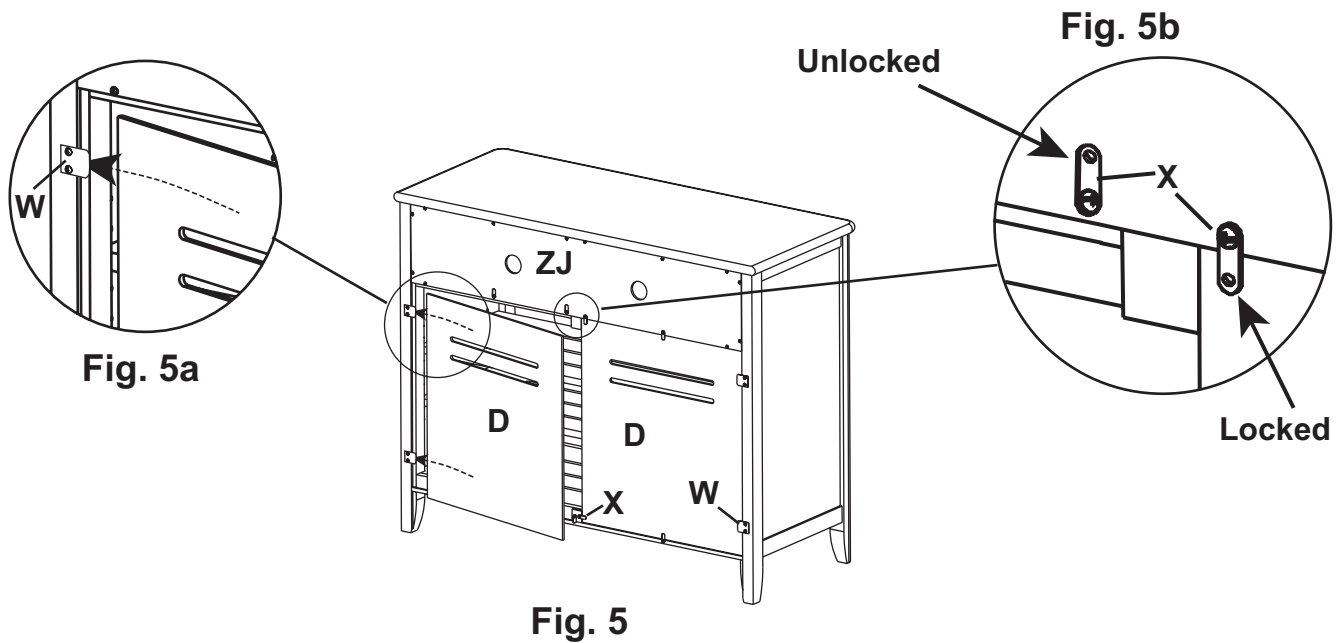

5. To insert your media components and access wires more easily, detach the Removable Backs (D). To do so, unlock the Turn Buttons (X) as shown in Figures 5 and 5b. Slide the Backs away and place them off to the side. After installing your components, slide the Backs behind the Drawer Stops (W) and lock the Turn Buttons (X). See Figures 5a and 5b.

Doors removed for illustration purposes.

Fig. 6

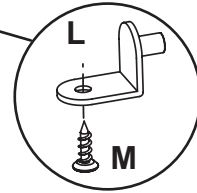
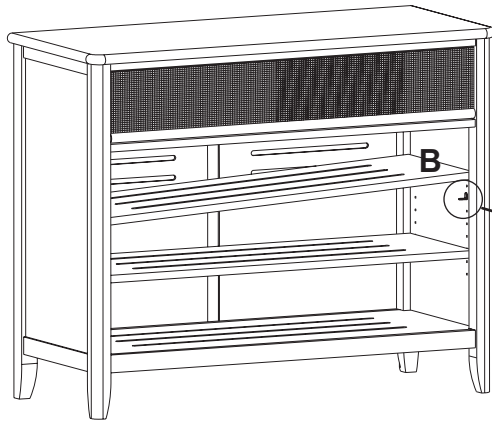

Fig. 6a

6. To move the Adjustable Shelves (B), remove the #6 x 1/2" Undercut Screws (M) and the Shelves (B). Reposition the Shelf Brackets (L), place the shelf on top and insert the screws. See Figures 6 and 6a.

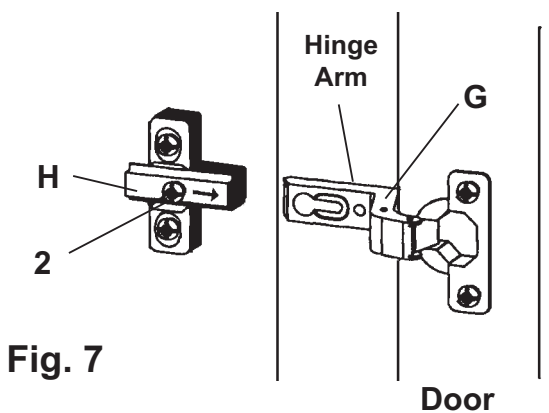

Fig. 7

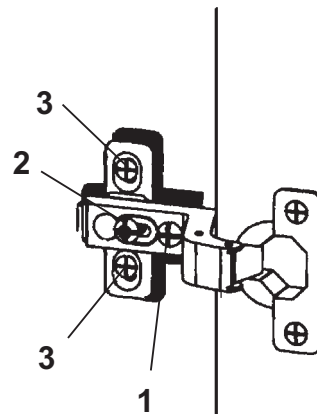

Fig. 7a

Side adjustment 4mm (5/32")

To move the door towards the side panel, loosen screw '1' and tighten screw '2'. To move the door away from the side panel, loosen screw '2' and tighten screw '1'.

Depth Adjustment 4mm (5/32")

Loosen screw '2' (just one turn), adjust the door to the desired position and re-tighten the screw.

Height Adjustment 4mm (5/32")

Loosen screw '3', adjust the door to the desired position and tighten the screw.

7. To adjust the doors, follow the above instructions.

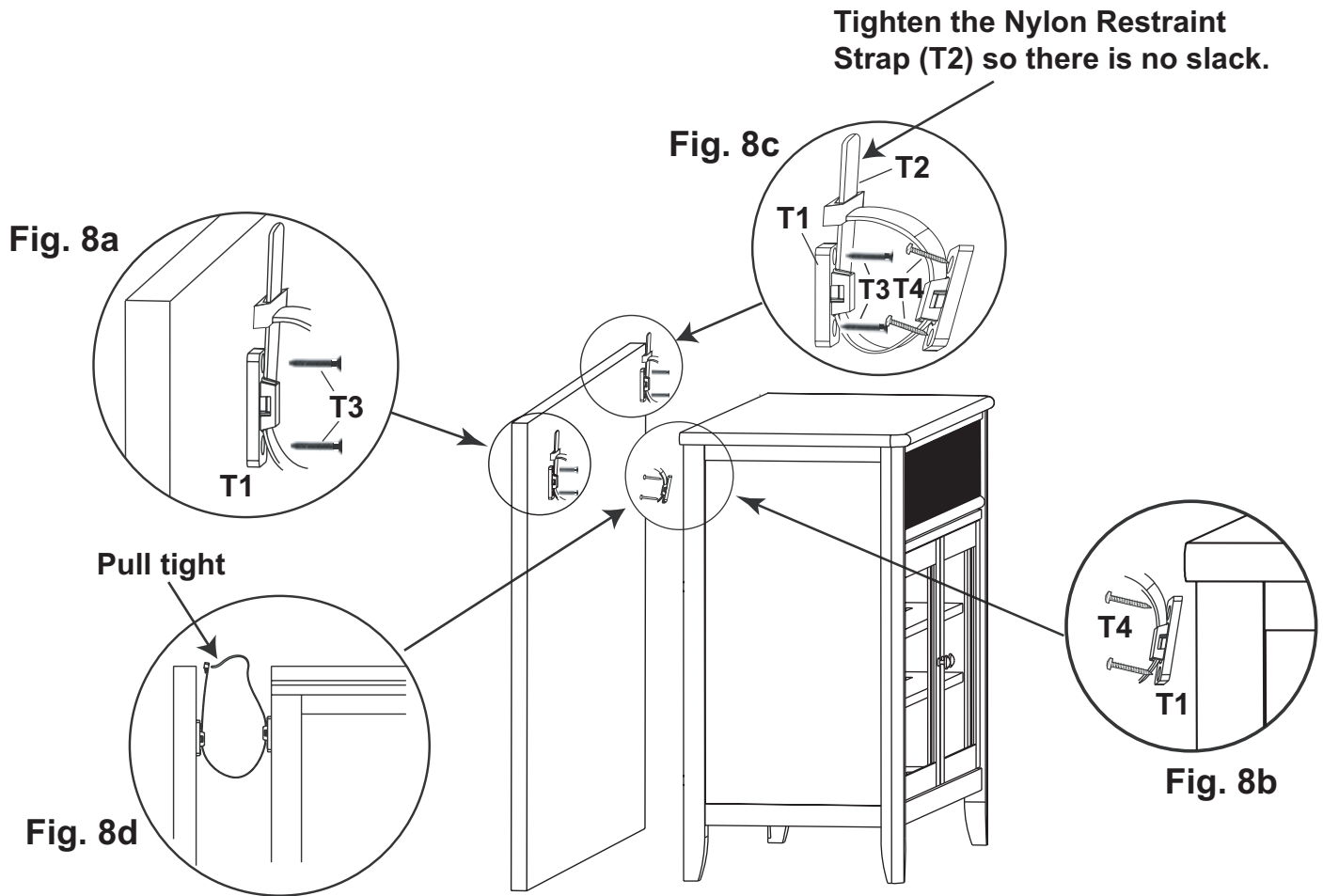

Tipping restraint:

8. Locate two studs in the wall behind the unit. Attach a Clip (T1) to one wall stud with two #8 x 2" Black Screws (T3). See Figure 8a. Attach a second clip to the unit with two #8 x 1" Pan head Screws (T4). See Figure 8b. Connect the two clips with the Nylon Restraint Strap (T2). Pull the Nylon Restraint Strap (T2) tight so there is no slack. See Figures 8c and 8d. Repeat this procedure to attach the second tipping restraint. If you cannot locate two studs, purchase the proper wall attachment hardware for your type of wall and secure the unit.